

# eme Gantry Crane Standard Models

SPEC SHEET · GANTRY LINE · 2026

**eme**

EASILY MOVED EQUIPMENT

MODEL	LIFT CAPACITY	STD BEAM LENGTH	A MIN/MAX TO LIFT EYE	B MAX TOP OF TROLLEY	C CLEAR SPAN	D WHEEL BASE (EST)	E HEIGHT ADJ. INC.	F CASTER SPREAD	G MIN TOP OF TROLLEY	ASSEMBLED WT <sup>1</sup>
<b>½ TONNE – 1 TONNE</b>										
1100R-8	1,100 lb	8 ft	66–90 in	106 in	5 ft	93 in	6 in	48 in	82 in	235 lb
2200R-8	2,200 lb	8 ft	66–90 in	106 in	5 ft	93 in	6 in	48 in	82 in	235 lb
2200LW-10	2,200 lb	10 ft	82–122 in	138 in	7 ft	117 in	8 in	65 in	98 in	285 lb
2200XT-15	2,200 lb	15 ft	120–176 in	191 in	12 ft	117 in	8 in	85 in	135 in	400 lb
2200MAX-15	2,200 lb	15 ft	164–252 in	268 in	12 ft	177 in	8 in	124 in	190 in	435 lb
<b>2 TONNE</b>										
4400M-10	4,400 lb	10 ft	66–90 in	106 in	7 ft	117 in	6 in	48 in	82 in	275 lb
4400R-10	4,400 lb	10 ft	82–122 in	138 in	7 ft	117 in	8 in	65 in	98 in	335 lb
4400T-15	4,400 lb	15 ft	98–138 in	154 in	12 ft	177 in	8 in	66 in	114 in	365 lb
4400XT-15	4,400 lb	15 ft	120–176 in	191 in	12 ft	177 in	8 in	85 in	135 in	400 lb
4400HELI-15	4,400 lb	15 ft	135–191 in	207 in	12 ft	177 in	8 in	85 in	150 in	480 lb
4400MAX-15	4,400 lb	15 ft	133–197 in	213 in	12 ft	177 in	8 in	106 in	149 in	635 lb
<b>3 &amp; 4 TONNE</b>										
6600R-15	6,600 lb	15 ft	106–154 in	179 in	12 ft	177 in	8 in	73 in	130 in	550 lb
6600MAX-15	6,600 lb	15 ft	136–216 in	240 in	12 ft	177 in	8 in	106 in	160 in	875 lb
8800MAX-15	8,800 lb	15 ft	136–216 in	240 in	12 ft	177 in	8 in	106 in	160 in	885 lb
<b>HIGH CAPACITY · 5 – 10 TONNE</b>										
11000R-15	11,000 lb	15 ft	106–154 in	179 in	12 ft	177 in	8 in	73 in	130 in	680 lb
11000R-25	11,000 lb	25 ft	106–154 in	182 in	22 ft	290 in	8 in	73 in	133 in	940 lb
22000R-15	22,000 lb	15 ft	97–139 in	169 in	12 ft	175 in	7 in	80 in	127 in	1,030 lb

<sup>1</sup> Assembled weight excludes the beam trolley. Beam trolley weights: 1100 / 2200 / 4400 series — 15 lb; 6600 / 11000 series — 35 lb; 22000 series — 70 lb. Different beam lengths are available for all models. Every unit is production-tested at 125% of rated capacity before shipment, on the Certificate of Test. Almost all eme gantry and davit designs are additionally qualified by a 150% proof-load test, documented on the P.Eng-stamped drawing. Each crane ships with a Certificate of Test and engineer-stamped drawing.

## REFERENCE DIMENSIONS

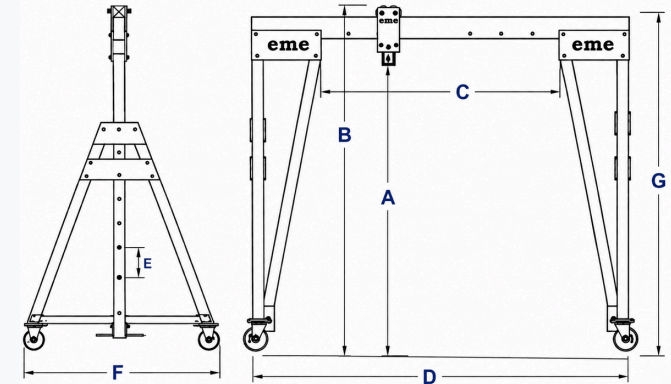

- A Min/Max to lift eye
- B Max top of trolley
- C Clear span
- D Wheel base
- E Height adj. increment
- F Caster spread
- G Min top of trolley

## STANDARD EQUIPMENT ON ALL MODELS

- All-aluminum construction
- 4-position swivel locking casters
- SAE J429 Grade 9 (Grade L9) fasteners
- Locking "Surround-Beam" trolley
- Proprietary box beam
- Height-adjustment handles

## STANDARDS, WELDING CERTIFICATION & TESTING

- Engineered to ASME B30.17, CSA B167, Aluminum Design Manual (ADM) & CSA S157
- Production-tested 125% · design
- Engineer-stamped drawing per unit
- Welded under CSA W47.2 certification by qualified aluminum welders
- Certificate of Test ships with every unit qualified 150%
- 10-year warranty · 2-year casters

## CONTACT

PHONE 1-888-679-5283  
 SALES [solutions@easilymovedequipment.com](mailto:solutions@easilymovedequipment.com)  
 PARTS [parts@easilymovedequipment.com](mailto:parts@easilymovedequipment.com)  
 WEB [easilymovedequipment.com](http://easilymovedequipment.com)